

## Branch Offices:

### AHMEDABAD

B-802, Iscon Elegance, Nr. Prahlad Nagar Corner, Opp. Karnavati Club, S.G. Highway, Ahmedabad-380051  
Ph.: 079 - 66168835/36  
E-mail: ahmedabad@hplindia.com

### BANGALORE

No.2D, 11nd Floor, Farah Winsford, 133, Infantry Road, Bangalore - 560001  
Ph.: 080-22863068/69  
E-mail: bangalore@hplindia.com

### BHUBANESWAR

N3-135, IRC Village, Nayabali, Behind Old Sai Baba Temple, Bhubaneswar-751012, Ph.: 0674-2550826  
E-mail: orissa@hplindia.com

### CHANDIGARH

SCO-14, 1st Floor, Industrial & Business Park, Phase-II, Chandigarh-160002  
Ph.: 0172-2639157/ 814640444  
E-mail: chandigarh@hplindia.com

### CHENNAI

"Amar Sindur" S-4, 2nd Floor, No.-43, Pantheon Road, Egmore, Chennai-600 008  
Ph.: 044-28551530, 28551537  
Fax: 044-42638243  
E-mail: chennai@hplindia.com

### COCHIN

1st Floor, A.K.S. Mahal Building, XL/7813J, Achutha Warriar Lane, M.G.Road, Ernakulam, Cochin-682035  
Telefax: 0484-2354595  
E-mail: cochin@hplindia.com

### COIMBATORE

Designer Complex, Door No.130, C/2, 2nd Floor, Dr. Nanjappa Road, Coimbatore - 641018, Ph.: 0422-4393995  
E-mail: coimbatore@hplindia.com

### DEHRADUN

09/4/6, 1st Floor, East Canal Road, (Near Doon Defence Academy) Dehradun-248001  
Ph.: 0135-2664387, 2664367  
E-mail: praveensharma@hplindia.com

### GUWAHATI

Rajgarh Road, Opposite China Town Restaurant, Guwahati-781003  
Ph.: 0361-2450889  
E-mail: guwahati@hplindia.com

### HUBLI

9-10, 1st Floor, Vernekar Plaza, Desh Pande Nagar, Hubli-580029  
Ph.: 0836-4251463  
E-mail: hubli@hplindia.com

### HYDERABAD

No. 7-1-58, Flat No.403, 4th Floor, Concourse Building, Green Lands Road, Hyderabad-500016, Ph.: 040-66687878  
E-mail: hyderabad@hplindia.com

### INDORE

203, Millinda Manor 2, RNT Marg, Near Ravindra Natya Grah, Indore-452001, Ph.: 0731-4280525, 4225540  
E-mail: Indore@hplindia.com

### JAIPUR

512, 5th Floor, Plot No. 8-9, Corporate Park, Gopal Bari, Ajmer Road, Jaipur-302001  
Ph.: 0141-4021035  
E-Mail: jaipur@hplindia.com

### JAMMU

Plot No.86, Yard No.6, Transport Nagar, Jammu-180006  
E-mail: jammu@hplindia.com

### KOLKATA

69, Ganesh Chandra Avenue, India House, 7th Floor, Block-C, Kolkata-700013  
Ph.: +91 9038094379  
E-Mail: calcutta@hplindia.com

### LUCKNOW

1st Floor, Jain Building, 14/A5, Park Road Hazratganj, Lucknow-226001  
Ph.: 0522-4021687  
E-Mail: lucknow@hplindia.com

### LUDHIANA

698 - D, Model Town Extn., Opp. Silverstone Hotel, Ludhiana-141003  
Ph.: 0161-4062877  
E-Mail: ludhiana@hplindia.com

### MUMBAI

2C/H, Rushabh Chambers, 2nd Floor, Off-Makwana Road, Near Rubi Hotel, Marol, Andheri East, Mumbai-400059  
E-mail: mumbai@hplindia.com

### NAGPUR

Jagtap House, Plot No. 07, 1st Floor, Ganesh Gruh Nirman Society, Near Ganesh Mandir, Ring Road, Pratap Nagar, Nagpur-440022, Ph.: 0712-2222988  
E-mail: nagpur@hplindia.com

### PATNA

Hem Plaza, 5th Floor - 510, Frazer Road, Patna-800001(Bihar), Ph.: +91 9334697299  
E-mail: patna@hplindia.com

### PUNE

Sunrise Skyline 3rd Floor, Plot No. 28/2 Scheme No. 11 B Opp. MSEB Office Somwar Peth Pune-411001 Ph.: +91 9028032724  
E-mail: pune@hplindia.com

### RAIPUR

1st Floor, Near Holy Heart School Chattisgarh College Road, Civil Line, Raipur (C.G.)-492006, Ph.: 0771-4218002/04  
E-mail: raipur@hplindia.com

### RANCHI

203, 2nd Floor, Mahalaxmi Complex, Line Tank Road, Ranchi-834001  
Telefax: 0651-2206144  
E-mail: ranchi@hplindia.com

### SILIGURI

1st Floor, Parasuna Bhawan, Ward No.13, Udhm Singh Sarani, Asram Para, Siliguri-734001  
E-mail: siliguri@hplindia.com

### VADODARA

409/410, Silver Oak Complex, Near Sainik Park, Char Rasta, Productivity Road, Akota, Vadodara - 390020 Gujarat  
Ph.: 0265-2341747, Fax:0265-2352107  
E-mail: baroda@hplindia.com

### VIJAYAWADA

D.No.-29-37-135, 2nd Floor, G. R. Plaza, Eluru Road, Beside Canara Bank, Vijayawada-520002 Ph.: 0866-6622291  
E-mail: vijayawada@hplindia.com

### VIZAG

B.K. Towers, 49-34-1/63, 3rd Floor Akka Yyapalem Main Road, NH-5 Junction, Vizag-530016 (A.P.), Ph.: 0891-2794506  
E-mail: vizag@hplindia.com

## Resident Offices:

Agartala	Balasore	Davangere	Jharsuguda	Moradabad	Silchar	Vapi
Agra	Belgaum	Durg	Jodhpur	Mysore	Surat	Varanasi
Allahabad	Berhampur	Goa	Kanyakumari	Nagercoil	Sholapur	Vellore
Anantpuram	Bhilai	Gorakhpur	Kolhapur	Nasik	Srinagar	
Aurangabad	Bhopal	Gulbarga	Kota	Patiala	Sambalpur	
Amravati	Bilaspur	Jabalpur	Madurai	Pondicherry	Tirupati	
Akola	Bijapur	Jabli	Malda	Rajkot	Trichy	
Angul	Calicut	Jamshedpur	Mangalore	Rourkela	Trivandrum	
Bareilly	Cuttack	Jalandhar	Meerut	Salem	Udaipur	

AV ATS 05/20



# AV ATS

## Advance Version Automatic load Transfer Switch

### Changeover applications 40A-630A



## HPL Electric & Power Ltd

Corp. Office: Windsor Business Park, B-1D, Sector-10, Noida, U.P. - 201301, INDIA.

Tel.: +91-120-4656300, Fax: +91-120-4656333

Registered Office: 1/20, Asaf Ali Road, New Delhi - 110 002, INDIA.

E-mail: hpl@hplindia.com

Customer Care No. :

18004190198

www.hplindia.com



www.hplindia.com

# AV ATS

Advance Version Automatic load Transfer Switch

from 40A-630A

**new**



**AV ATS**  
Advance Version Automatic load Transfer Switch  
from 40A - 630A

Founded in 1956, the HPL Group is a major player in Indian Electrical Industry with commitment to the state of art technology, manufacturing world class products. HPL Group has been serving Indian Industry since last 55 years with time tested, reliable and well -proven products in the field of Switchgears, Protection Devices, Electronic Energy Meters, Energy Management Systems, CFL Lamps, Luminaries, Wire & Cable, LED Lighting & Modular Switches

HPL Group has created niche for it self in Electrical Industry. Upgradation of existing technology and introduction of new products with innovative ideas and new technology are the main driving force here.

HPL brings to you, **AV ATS** range of True 4 pole motor operated changeover switches with positive break indication. They enable the on load transfer of two three-phase supplies via remote volt-free contacts, from either external automatic controllers, using pulse logic, or Push Button Station.

They are intended for use in low voltage power systems where interruption of the load supply is acceptable during transfer.

### The solution for

- > Generator manufacturers.
- > Heating.
- > Air conditioning.
- > Ventilation.
- > Telecommunications.



### Strong points

- > Extensive power supply range.
- > Safety and reliability.
- > Easy integration.
- > Simplified maintenance.
- > ATyS Sd Dual power supply.

### Conformity to standards

- > IEC 60947-6-1
- IEC 60947-3
- CE Marked
- RoHS Compliant



## Approvals & Test

- Time tested
- Customer Accepted
- CPRI Tested
- ISO 9001 Certified



Globally Accepted  
exporting to over  
**25 countries**



### Salient Features:

- A simple strong and reliable mechanism to provide a safe changeover of sources, remotely.
- The only Switch with RoHS Compliance studded with protections like Phase Barriers, Source Separators, Terminal Cover.
- The only ATS with Protection against Arc.
- The FR molding material of the switch is having high thermal withstand capacity.
- AV ATS is True 4 Pole switch available in 4 frame sizes with AC 23A & AC-31B Load switching duty.
- AV ATS is available with 3 positions I-O-II Manual & Electrical Operations with non defeatable mechanical interlock.
- The AV ATS can be put in 'O' position both by manual operation through emergency handle & Electrical Operation through emergency switch.
- In the AV ATS the contacts opening / closing is within self extinguishing reinforced fiberglass body with arc chutes for quick & better arc extinguishing.
- For all versions, the quick make and quick break feature independent of the operating speed enables the switches to close and open circuits under the most severe conditions (e.g. highly inductive loads-AC 23A duty).
- The manual and electrical operation are interlocked and the manual operation is done with the handle provided with.
- The motor module is detachable & wide range of spares allow on site repair solutions.
- The Basic Controller & Higher Version Controller are available for advance auto switching with Communication facility.

### Applications

- > Healthcare
- > Internet Data Centers
- > Commercial Buildings
- > Industrial Buildings
- > Residential Buildings
- > Telecom Central Office
- > Process Manufacturing
- > Distribution Power / Load Management
- > HVAC
- > Telecommunications
- > BMS

### Installation

- HPL Changeover switches are ideal choice for installation in A.M.F. panel or for remote operation.
- Connection on terminal is very easy, as they are large and accessible.

### Conformity

IS/IEC: 60947-3 & IEC: 60947-6-1  
CE Marked  
RoHS Compliant

### Range

AC 23A 415VAC 4 Pole 40A to 630A in 4 frame sizes.

### General Characteristics

The ideal conception in HPL AV ATS changeover switch incorporate 3 stable positions (I-O-II) changeover ensuring isolation of 2 asynchronous power supply.

#### Positions:

- O - Circuit I and II Open (Neutral Position)
- I - Circuit -I close and circuit II open (transformer supply "ON" and generator supply "OFF")
- II - Circuit I open and Circuit II close (generator supply "ON" and transformer supply "OFF")

All positions are interlocked

### Functions

HPL AV ATS CHANGEOVER SWITCHES 'operate as a Changeover giving three stable positions I-O-II and help in supply changeover from one source to another' remotely.

### Design

AV ATS Changeover Switches are manufactured from AV Changeover moulded case on load switches. In case of control supply failure, Emergency Handle arrangement is provided for manual operation of switch in "OFF" position or selecting the supply. The switch frames are back to back. The whole range is motor operated.

### Contact System

- Clearly apparent operation
- High thermal and dynamic strength to withstand rated fused short circuit current level 80KA rms.
- Are rated for AC-23A utilisation category.

### Factory Fitted Auxiliary Contacts

- The auxiliary contacts are of "CO" type, they provide position signal or prebreak control.
- The auxiliary contacts are pre-wired for more convenience during installations.
- The auxiliary contacts 1NO 1NC and 2NO 2NC are available



## Advantages



### Compactness

It is very compact in size and hence helps in saving space in the enclosures, panels etc. Due to its slim size uses the distribution space very efficiently regardless of fact whether it is in residential or funtional buildings.



### Simplicity

Its handling is easy and simple. Its simplicity and ease in use allows the user for quick installation. Any pole can be used as Neutral pole. Line load reversibility supports user in comer and out going design. Plugin auxiliary contact kit easy to mount on the switch. Grove to insert safety shield



### Total Safety

Its is very safe to use. all moving parts and live parts are covered eliminating possibilities of casualties & electric shocks. The insulation property of the material used is highly reliable, self extinguishing with high insulating properties and remains intact in even critical conditions. arch chute chamber evades fire in surges

## Isolation Function:

These Onload changeover switches are Suitable for Isolation as per IS/IEC 60947-3. Isolation function highlights the following points:-

- Position of main contact is indicated clearly by a separate mechanical indicator.
- No residual current



**Positive isolation  
no room for surges**



## Characteristics according to IEC 60947-3 and IEC 60947-6-1

### 125 to 630A

Specification	Current Rating											
	Frame Sizes					Frame-0		Frame-1		Frame-2		Frame-3
	40A	63A	80A	100A	125A	125A	160A	200A	250A	320A	400A	630A
Thermal Current (Ith) 40°C	40A	63A	80A	100A	125A	125A	160A	200A	250A	320A	400A	630A
Rated Insulation voltage Ui (Vac)	750	750	750	750	750	1000	1000	1000	1000	1000	1000	1000
Dielectric strength (Vac) 50 Hz 1 minute	4000	4000	4000	4000	4000	5000	5000	5000	5000	5000	8000	8000
Impulse voltage (KV)	6	6	6	6	6	6	6	8	8	8	12	12
Number of Poles	4	4	4	4	4	4	4	4	4	4	4	4

### Rated Operational Current Ie (A) According to IS/IEC: 60947-3

415 Vac: AC 23A	40	63	80	100	125	125	160	200	250	320	400	630
500 Vac: AC 23A	40	55	55	55	55	100	130	160	200	250	315	315
260V dc: DC 21A	40	63	80	100	125	125	160	200	250	320	400	630
260V dc: DC 22A	40	63	80	100	125	125	160	200	250	320	400	500
260V dc: DC 23A	40	63	63	63	63	125	160	160	200	250	400	500
440V dc: DC 21A	40	63	80	100	125	125	160	200	250	320	400	500
440V dc: DC 22A	40	63	80	100	125	125	130	160	200	250	400	500
440V dc: DC 23A	40	63	63	63	63	125	130	160	200	250	400	500

### Rated Current & Voltage of motor

Current / Voltage	2A/230VAC & 2A/12VDC				2A/230VAC & 2A/48VDC			
-------------------	----------------------	--	--	--	----------------------	--	--	--

### Overload Capacity

Short circuit current with fuses (kA RMS)	80	80	80	80	80	80	80	80	80	80	80	80
Associated Fuse Rating	40	63	80	100	125	125	160	200	250	315	400	630
Peak short circuit making capacity (kA RMS)	15	15	15	15	15	20	20	20	30	45	45	45
Admissible short time current 1 sec (kA RMS)	5	5	5	5	5	7	7	7	13	13	13	13

### Making & Breaking Characteristics

Breaking capacity (A RMS) 415 Vac pf=0.35	320	504	640	800	1000	1000	1280	1600	2000	2520	3200	5040
Making capacity (A RMS) 415 Vac pf=0.35	400	630	800	1000	1250	1250	1600	2000	2500	3150	4000	6300

### Endurance

Mechanical Life (No. of Operations)	10000	10000	10000	10000	10000	8000	8000	8000	8000	5000	5000	5000
Electrical Life (No. of Operations)	2500	2500	1500	1500	1500	1000	1000	1000	1000	1000	1000	1000
Operating Torque ( N-m)	3.5	3.5	3.5	3.5	3.5	9.5	9.5	9.5	11	11	17	17

### Switching Time

I - II or II - I (s)	0.5	0.5	0.5	0.5	0.5	0.75	0.75	0.75	1.3	1.3	1.3	1.3
I - 0 or II - 0 (s)	0.25	0.25	0.25	0.25	0.25	0.45	0.45	0.45	0.85	0.85	0.85	0.85
Duration of "electrical blackout" I - II (s)	0.25	0.25	0.25	0.25	0.25	0.3	0.3	0.3	0.6	0.6	0.6	0.6

### Power Connection

(Details of Copper Conductors)

Min.Cu. Cable/Bus bar size (mm <sup>2</sup> )	10	16	25	35	50	50	70	95	120	185	240	2x185
---	----	----	----	----	----	----	----	----	-----	-----	-----	-------

(Details of Aluminum Conductors)

Min.Al. Cable/Bus bar size (mm <sup>2</sup> )	16	25	35	50	70	70	95	150	185	240	300	640
---	----	----	----	----	----	----	----	-----	-----	-----	-----	-----

Weight (Kgs) 4P	2.8	2.8	2.8	2.8	2.8	7.5	8	8	10.5	10.5	19	22
-----------------	-----	-----	-----	-----	-----	-----	---	---	------	------	----	----

# Controllers

Advance Version Automatic load Transfer Switch



CM 331 & CM335 is an Automatic Transfer Switch Controller. Controller will monitor the voltage and frequency of the incoming AC supply from two different sources, which could be from both generator or mains (utility), or a combination of both. The module will monitor S1 (Source 1) and in the event of failure will issue a start command to S2 (Source 2)

Once S2 is available and producing an output within limits, the module will control the transfer device and switch the load from S1 to S2. Once the S1 supply returns to within limits, the module will command a load return S1 and shut down S2.

## SPECIFICATION

### CM 331 & CM 335

#### • CRANKING DROPOUTS

Able to survive 0 V for 50mS, proving supply was atleast 10V before dropout and supply recovers to 5V. This is achieved without the need for internal batteries. LED's and backlight will not be maintained during cranking.

#### • CRANKING DROPOUTS

168mA at 12 V, 80mA at 24V in CM 331  
480mA at 12 V, 30 mA at 24 V in CM 335

#### • MAXIMUM STANDBY CURRENT

39mA at 12V, 20 mA at 24V in CM 331  
126mA at 12V, 96 mA at 24V in CM 335



## Key Benefits of CM 335

- Configurable inputs(12)
- Configurable volt-free outputs (6)
- Configurable DC outputs (6)
- 4 Line back-lite LCD text display
- Five key menu navigation
- Front panel editing with PIN protection
- LED & LCD alarm indication
- Source 1 / Source 2 control
- Start & Load inhibit
- Manual restore to S1
- Configurable timers and alarms
- Multiple date and time scheduler
- Power monitoring (kW h, kV Ar, kV A h, kV Ar h)
- USB Connectivity
- Backed up real time clock
- Fully configurable via Controller
- Configuration Suite PC software
- Configurable display languages
- User selectable Rs232 and Rs485 communications



- SMS messaging (additional external modem required)
- Expansion compatible
- Integral PLC editor
- Modules can be integrated into buildings management systems (BMS)

## General Characteristics of ATS CM 331 & CM 335

### General Characteristics of ATS CM 331

- Switches power when mains (utility) supply fails and switches back when mains (utility) supply returns.
- Allows flexible control of source inputs.
- Provides multiple installation options.
- Provides alternator breaker type control.
- Allows flexible control of source inputs.
- Ensures the smoothest possible transfer is achieved.
- Gives true on screen information for all 3-power phases.
- Provides complete user-friendly configuration and easy-to-use high-level system control & monitoring

### General Characteristics of ATS CM 335

- Allows flexible control of source inputs.
- Provides multiple installation options.
- Provides clear accurate power measurement information.
- Allows flexible control of source inputs.
- Ensures the smoothest possible transfer is achieved.
- Ensures additional applications are easily integrated into the system.
- Provides secure and simple off site monitoring. All ports are continuously active.
- Provides alternator breaker type control.
- Provides complete user-friendly configuration and easy-to-use high-level system control & monitoring.
- Provides access to historical alarms and operational status.

## Key Features of CM 331

- Configurable inputs(4)
- Configurable volt-free outputs (4)
- Configurable DC outputs (4)
- Icon or English text display
- LED indicator
- Front Panel / PC configuration
- Source 1 / Source 2 control
- Configurable Timers
- Start inhibit
- Load inhibit
- Manual restore to S1
- Automatic switch-over between supplies
- Single event scheduler
- 3-phase display



## Functions of ATS CM 331 & CM 335

### ATS CM 331

- Automatic switch over between supplies.
- Manual restore to S1.
- Configurable inputs/outputs (4/8). 4 configurable volt-free outputs & 4 configurable DC outputs.
- Rotary ATS configuration.
- Source 1/source 2 control.
- 3-phase display.
- Panel editor/Configuration PC suite licence free

### ATS CM 335

- Automatic switch over between supplies.
- Manual restore to S1.
- Configurable inputs/outputs (12/12). 6 configurable volt-free outputs & 6 configurable DC outputs.
- Power & Energy Parameters monitoring (kWh, kVAR, kVAh, kVArh).
- Source 1/source 2 control.
- Integral PLC editor.
- RS232 & RS485 communications (user selectable).
- Rotary ATS configuration.
- Configurable event log (250).
- Panel editor/Configuration PC suite licence free.



## Description of CM 331 Controller

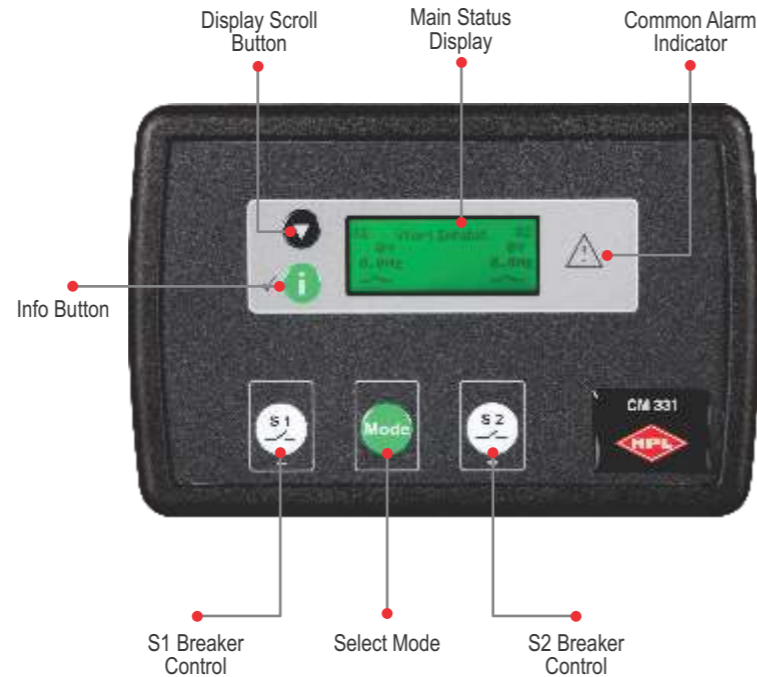

## Description of CM335 Controller

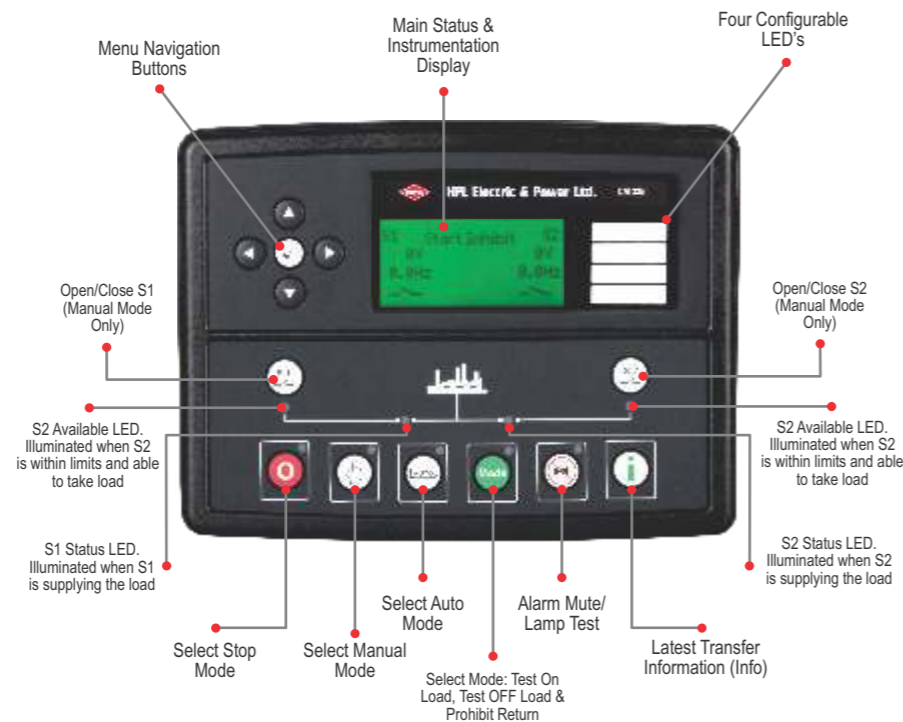

## Dimensions of CM 331 & CM 335

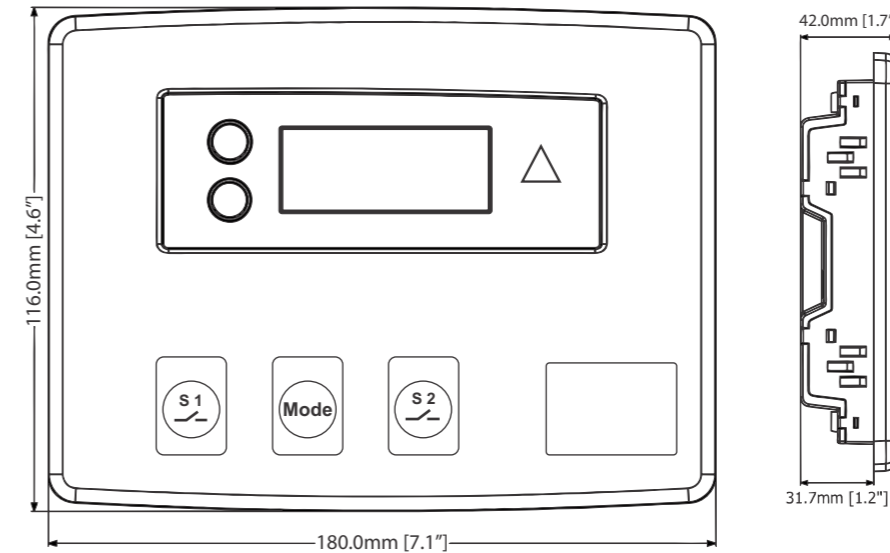

<b>Dimensions</b> 180mm x 116mm x 42mm (7.1" x 4.6" x 1.7")	<b>Panel Cutout</b> 154mm x 98mm (6" x 3.9")	<b>Weight</b> 400g (0.4kg)
---	--	-------------------------------



Fixing Clip fitted to Module



Fixing Clip

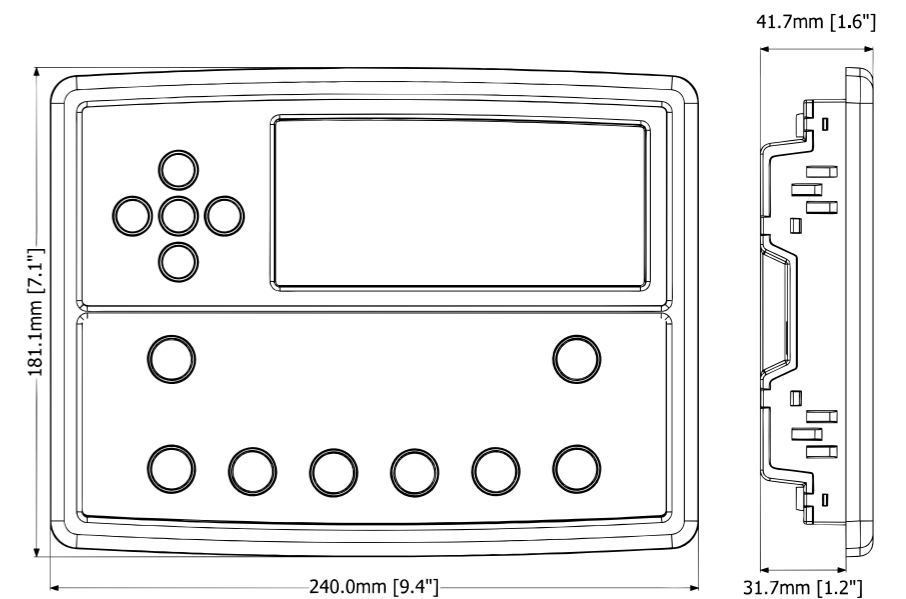

<b>Dimensions</b> 240mm x 181.1mm x 41.7mm (9.4" x 7.1" x 1.6")	<b>Panel Cutout</b> 220mm x 160mm (8.7" x 6.3")	<b>Weight</b> 700g (0.7kg)
---	---	-------------------------------



Fixing Clip fitted to Module



Fixing Clip



**ATS Switch Connections**

- P** = Power Indication
- I** = Source - 1
- II** = Source - 2
- O** = Neutral
- C** = Common

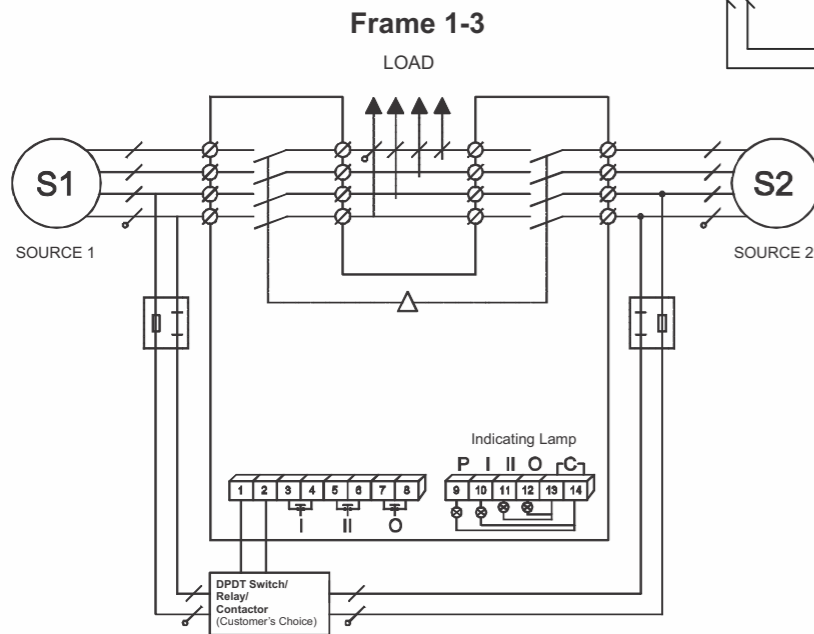
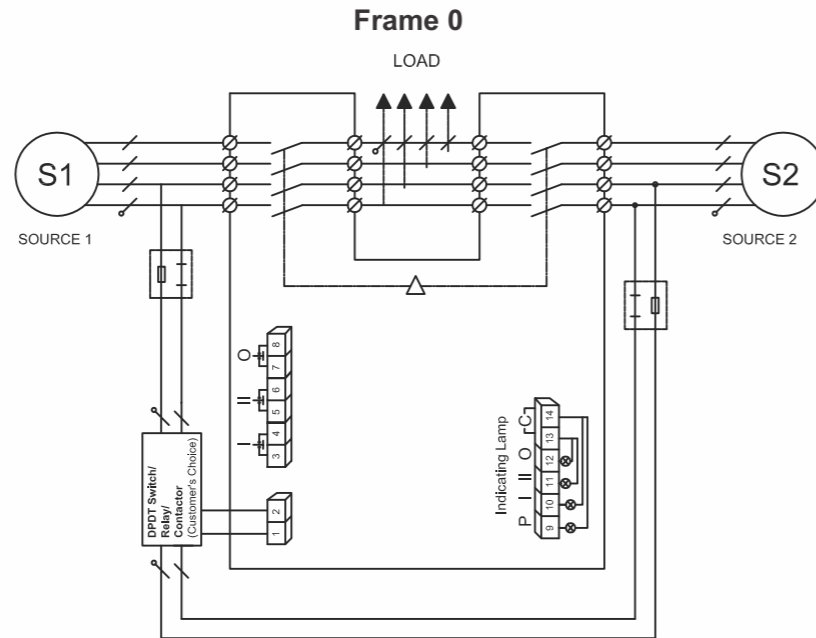

- P** = Power Indication
- I** = Source - 1
- II** = Source - 2
- O** = Neutral
- C** = Common

DETAILS	TERMINAL No.	DESCRIPTION	PARAMETERS	CABLE SIZE REQD.
Power Supply	①	Power Supply	230 Vac ±20%	1.5 Sq.mm
Control	②			
	③	Position-I Command	 <b>DO NOT CONNECT TO POWER SUPPLY</b>	
	④	Position-II Command		
	⑤	Position-O Command		
	⑥	Position-O Command		
Signaling	⑨ ~ ⑭	Power Indicator	5A, 230 Vac OUTPUT	
	⑩ ~ ⑭	Position-I Indicator		
	⑪ ~ ⑬	Position-II Indicator		
	⑫ ~ ⑬	Position-O Indicator		



**ATS Frame 0 with CM 331 Controller Connection**

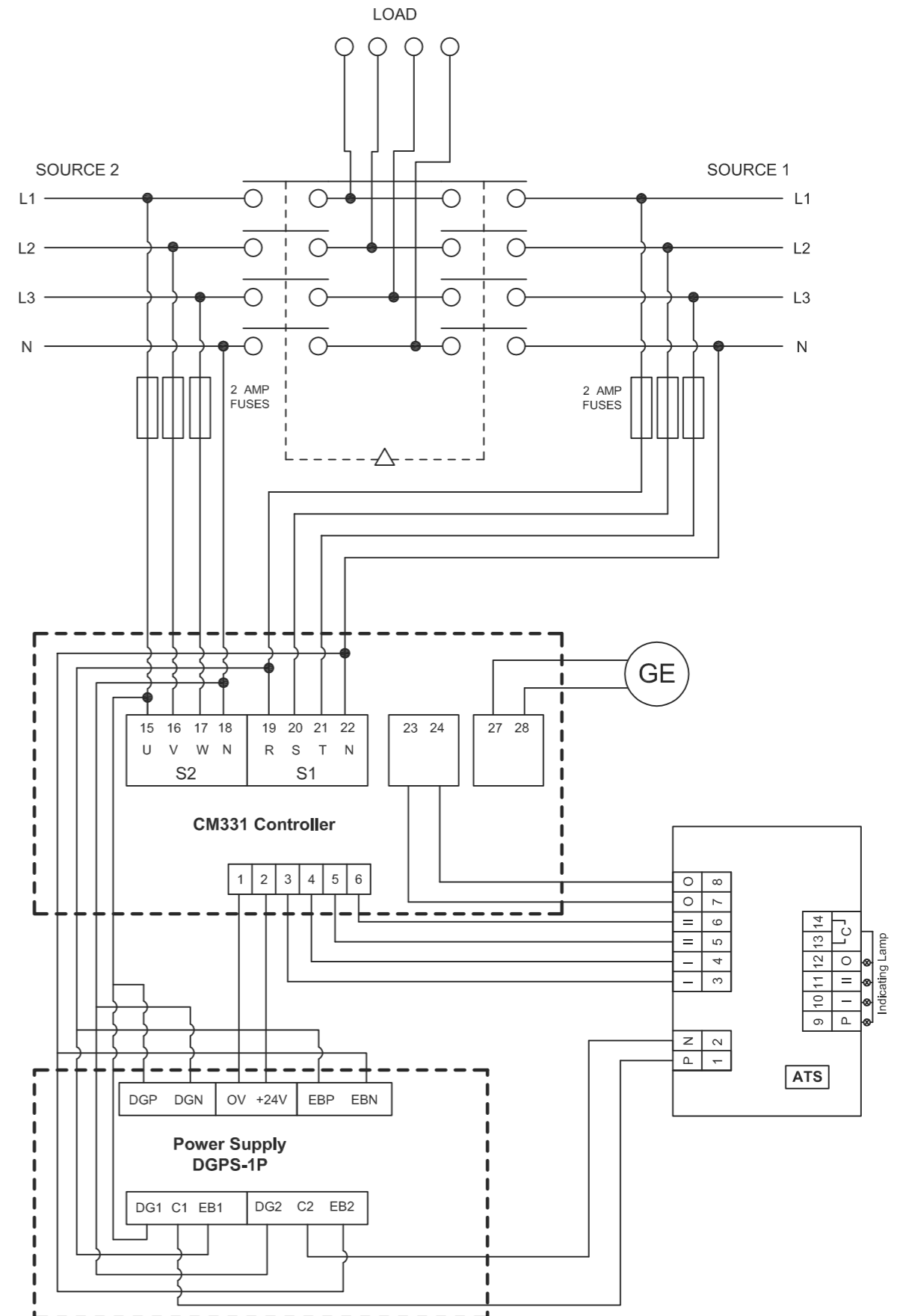



**ATS Frame 1-3 with CM 331 Controller Connection**

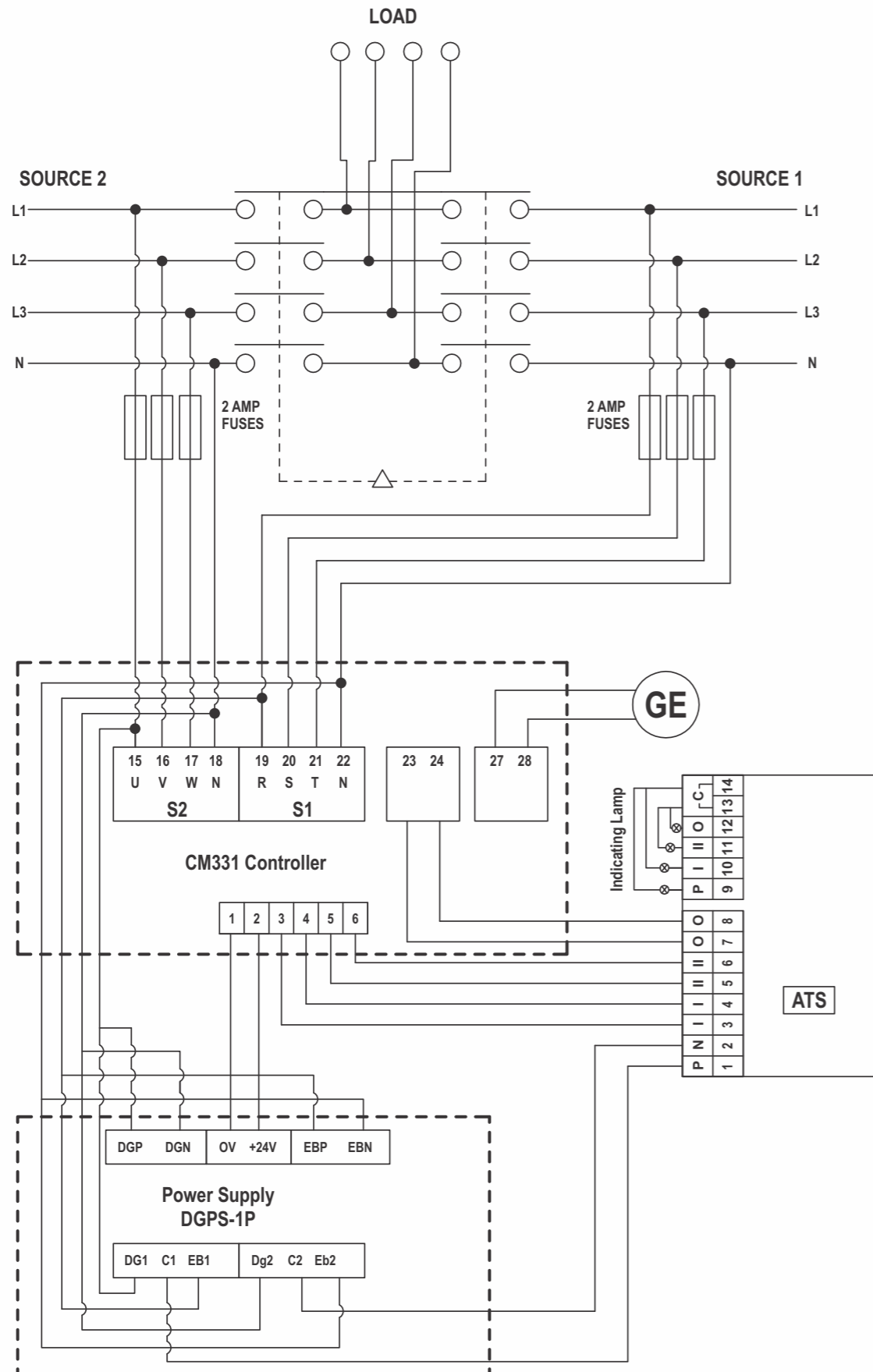

**ATS Frame 0 with CM 335 Controller Connection**

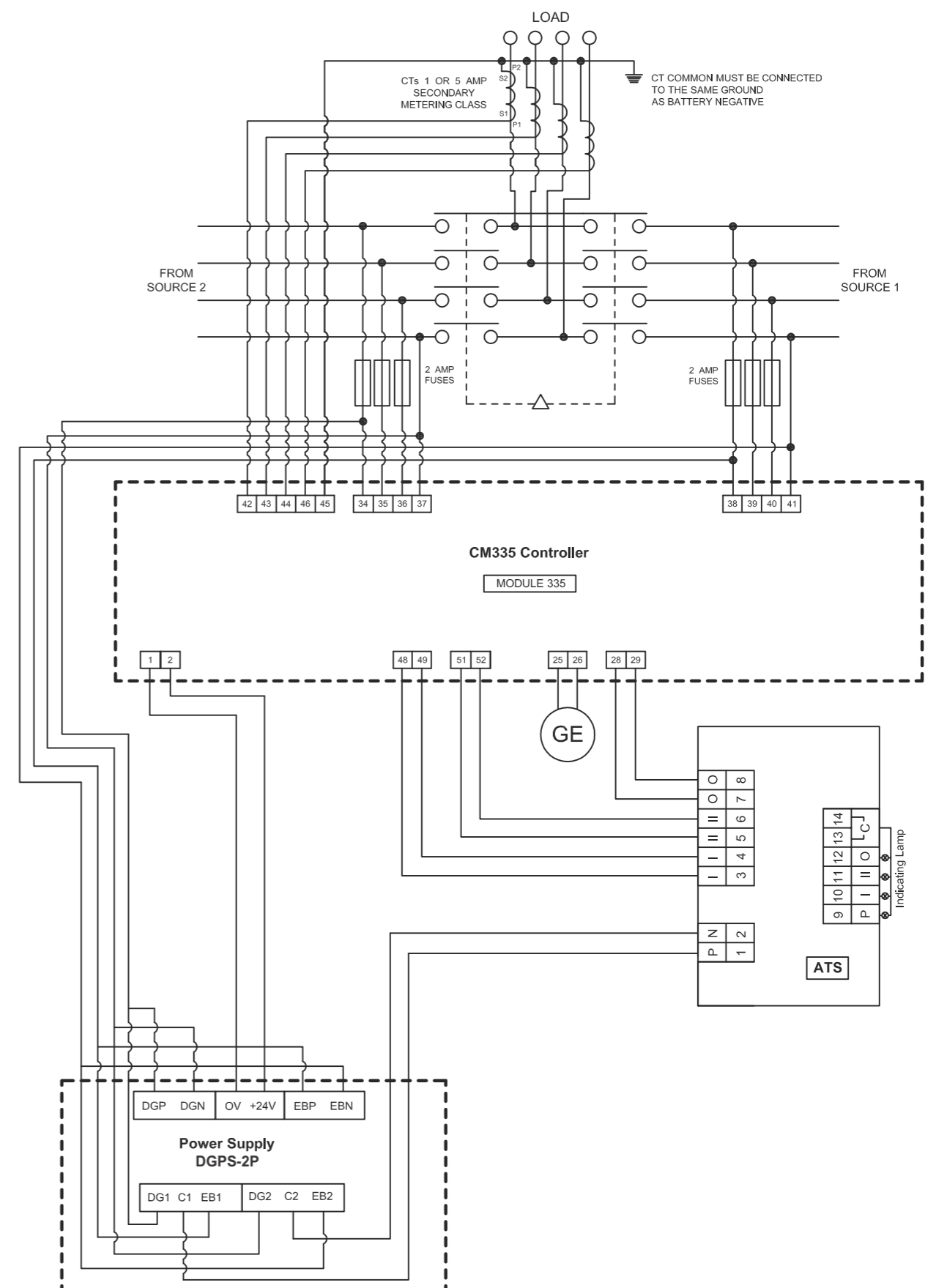



**ATS Frame 1-3 with CM 335 Controller Connection**

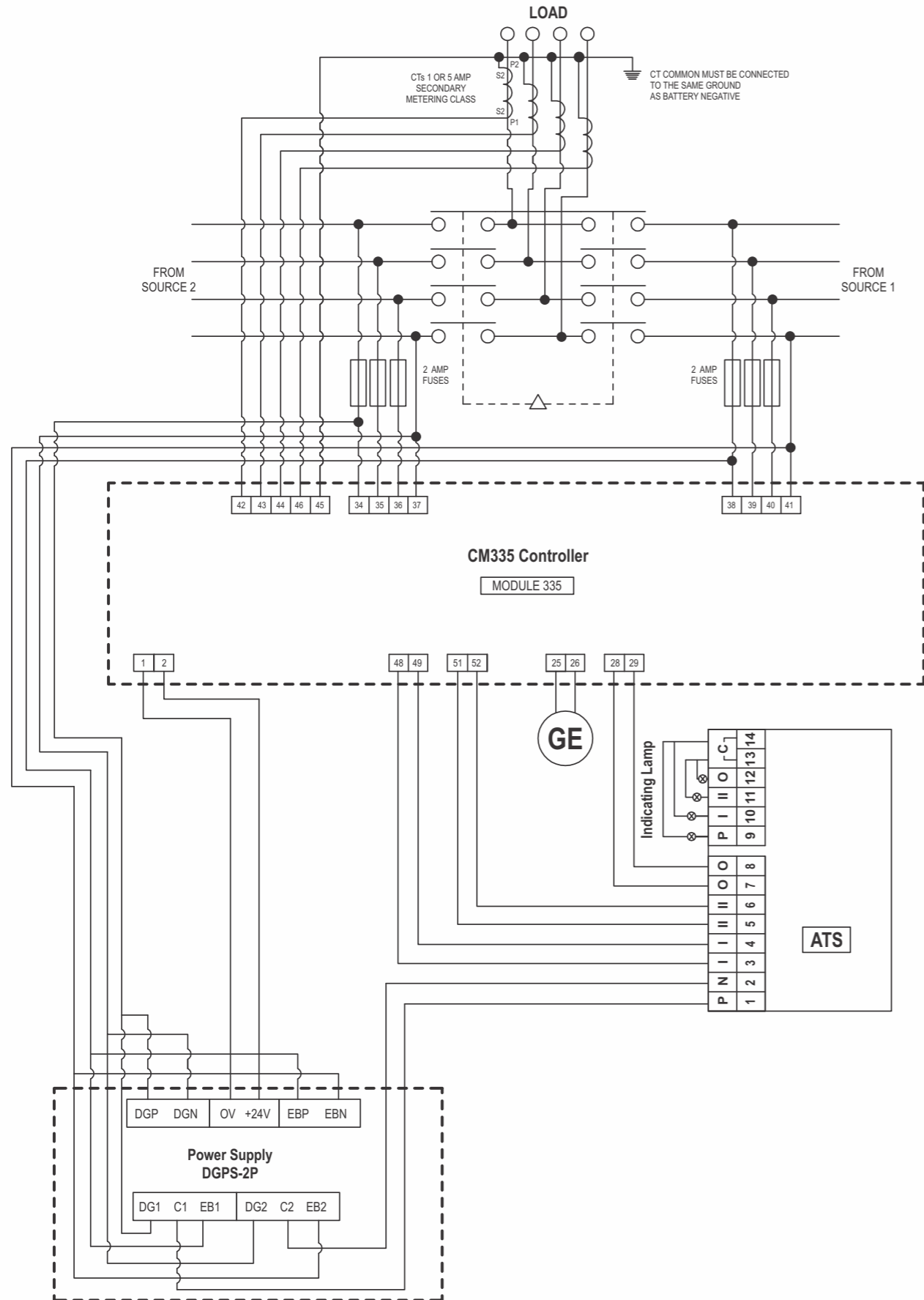

**Accessories**

- **Source Separator**  
Evades any possibility of source shorting.
- **Phase Barrier**  
Possibility of accidental shorting between the phases is completely eradicated.

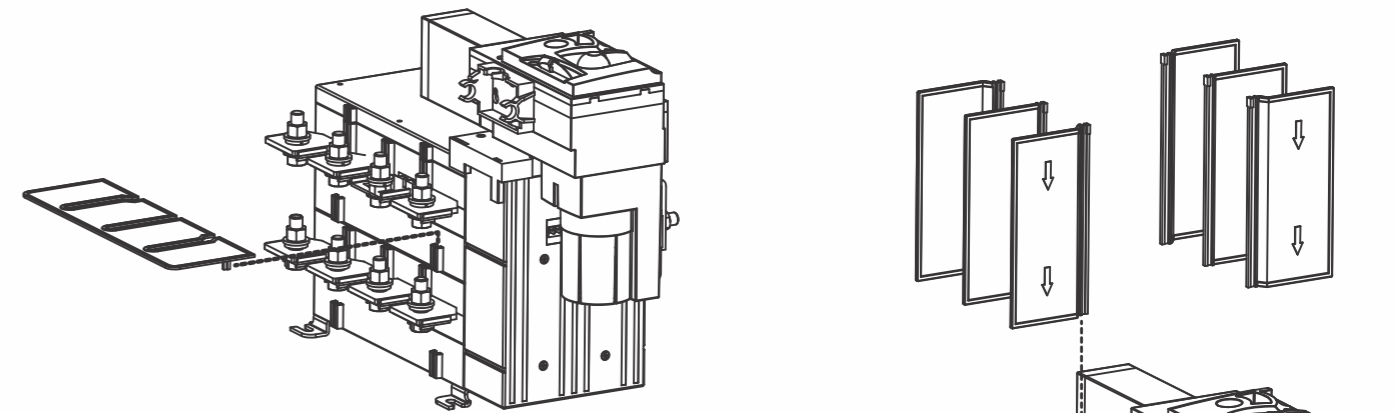

- **Terminal Cover**  
Protects touching the live parts unknowingly.

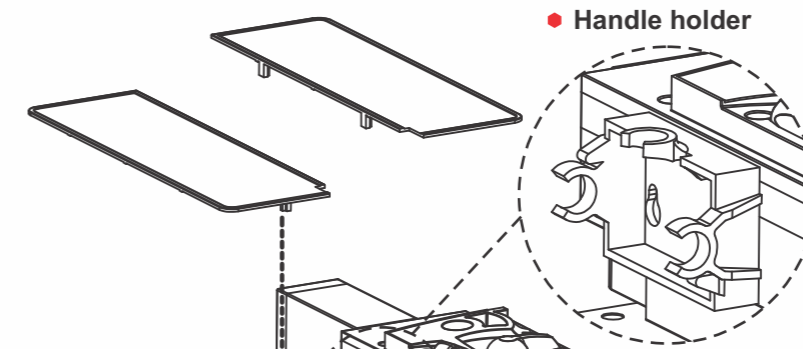

- **Manual / Auto Inter Lock**  
Allows either Manual or Automatic operations at once.

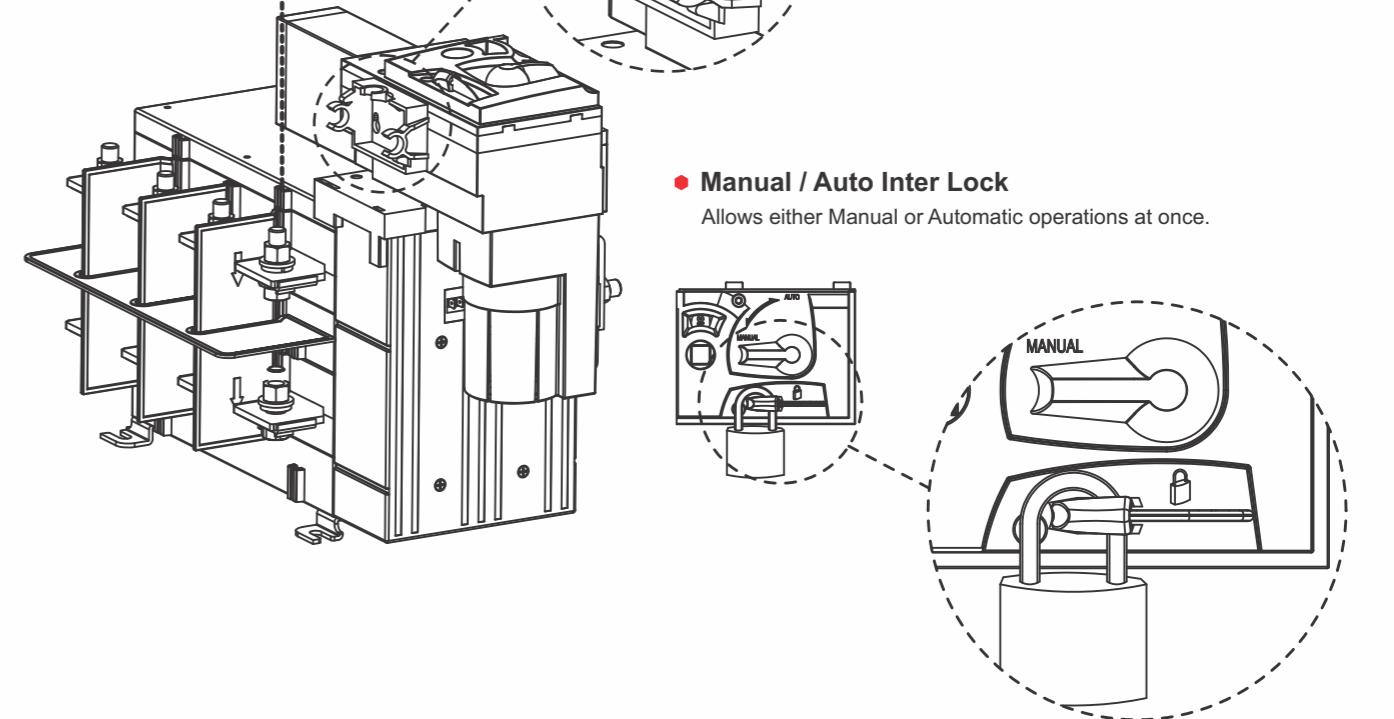





**Terminals and connections for Auxiliary Contacts**

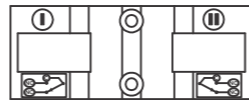
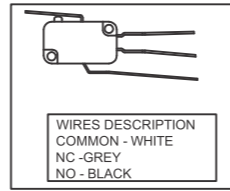
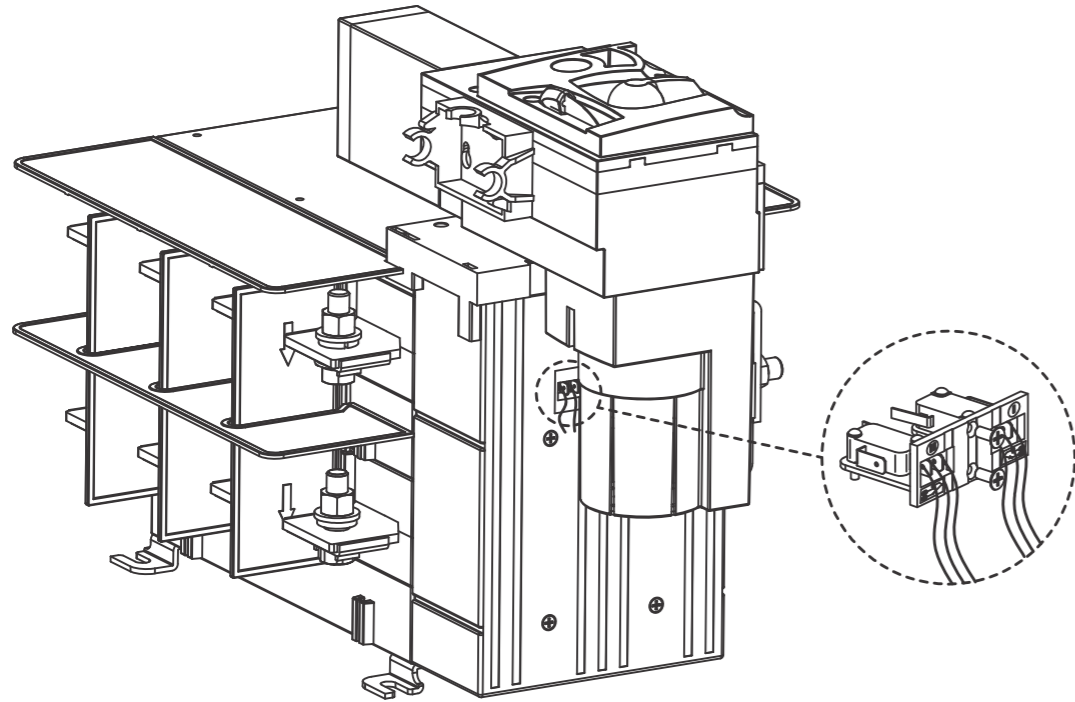

**Mounting Orientation**

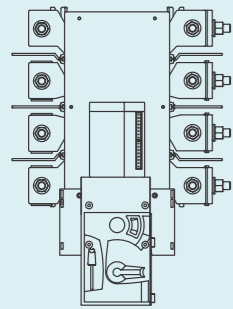

Possible

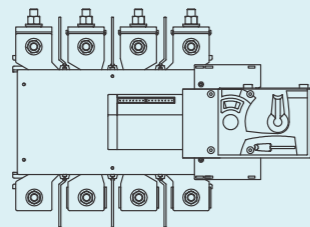

Recommended

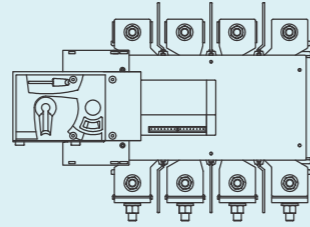

Forbidden

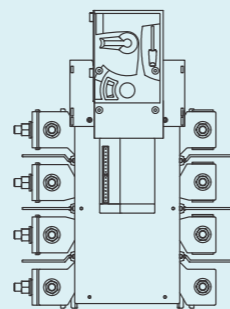

Forbidden

**Dimension Enclosure**

Rating	L	W	Y	X	H
40A - 125A	350	400	398	350	300
125A - 200A	450	500	497	450	359
250A - 320A	550	600	598	550	399
400A - 630A	650	700	690	600	469

Note: All dimensions in mm (Tolerance ±5%)

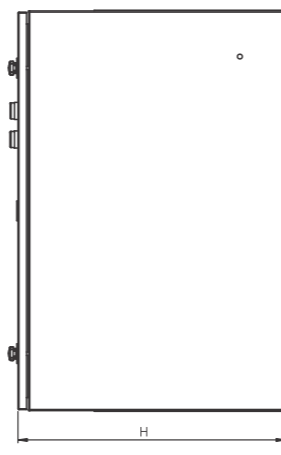
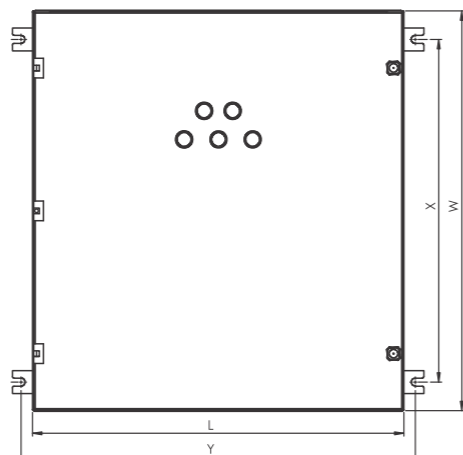

**Dimension**

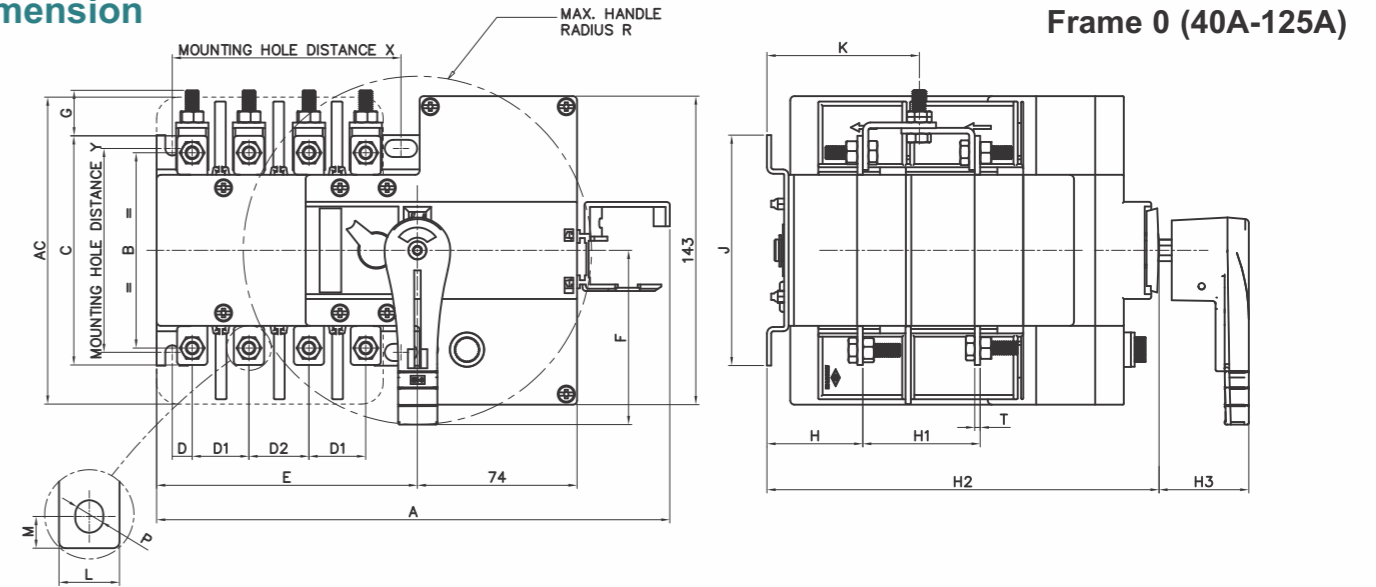

Rating	Mounting Hole Dist.		A	B	C	D	D1	D2	E	F	G	H	H1	H2	H3	J	K	L	M	P	R	T	AC
	X	Y																					
40A	106	95	238	91	106	9	26	28	121	81	22	44	54	182	42	107	71	14	8	6.5	81	2.5	142
63A	106	95	238	91	106	9	26	28	121	81	22	44	54	182	42	107	71	14	8	6.5	81	2.5	142
80A	106	95	238	91	106	9	26	28	121	81	22	44	54	182	42	107	71	14	8	6.5	81	2.5	142
100A	106	95	238	91	106	9	28	29	121	81	22	44	54	182	42	107	71	15	8	6.5	81	2.5	142
125A	106	95	238	91	106	9	28	29	121	81	22	44	54	182	42	107	71	15	8	6.5	81	2.5	142

Note: All dimensions in mm (Tolerance ±5%)

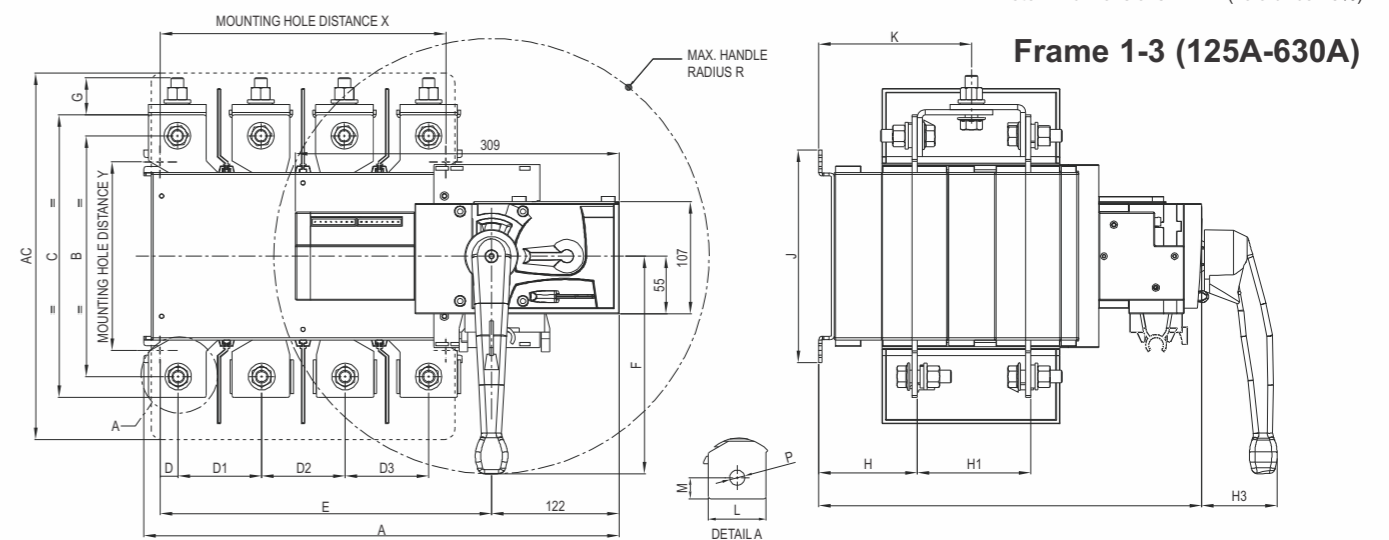

Rating	Mounting Hole Dist.		A	B	C	D	D1	D2	E	F	G	H	H1	H2	H3	J	K	L	M	P	R	T	AC
	X	Y																					
125A	158	95	316.5	117	141	12	45	45	183	151	35	64	66	278	54	115	95	22	16	10.5	151	3	195
160&200A	158	95	316.5	123	155	8	48	45	183	151	35	64	66	278	54	115	95	25	16	10.5	151	4	195
250&320A	215	111	375.5	152	192	7	64.5	64.5	240	208	35	72.5	75.5	298	72	130	107.5	32	20	11	208	4.5	240
400A	273	180	454	206	240	27	73	73	317	208	40	94.5	108.5	366	72	203	146	40	20	14.5	208	5	350
630A	273	180	454	230	270	17	80	80	317	208	40	94.5	108.5	366	72	203	146	55	20	14.5	208	5	350

Note: All dimensions in mm (Tolerance ±5%)



**Ordering Code for reference**

Frame	Rating In Amp	Motor operated switch in Open Execution	Motor operated switch in SS Enclosure	Motor operated switch with Controller CM331 in Open Execution	Motor operated switch with Controller CM331 in SS enclosure	Motor operated switch with Controller CM335 in Open Execution	Motor operated switch with Controller CM335 in SS enclosure
0	40	ATS0404POXS	ATS0404PEXS	ATS0404POS	ATS0404PES	ATS0404PO3S	ATS0404PE3S
	63	ATS0634POXS	ATS0634PEXS	ATS0634POS	ATS0634PES	ATS0634PO3S	ATS0634PE3S
	80	ATS0804POXS	ATS0804PEXS	ATS0804POS	ATS0804PES	ATS0804PO3S	ATS0804PE3S
	100	ATS1004POXS	ATS1004PEXS	ATS1004POS	ATS1004PES	ATS1004PO3S	ATS1004PE3S
	125	ATS1254POXS	ATS1254PEXS	ATS1254POS	ATS1254PES	ATS1254PO3S	ATS1254PE3S
1	125	ATS01254POXS	ATS01254PEXS	ATS01254POS	ATS01254PES	ATS01254PO3S	ATS01254PE3S
	160	ATS01604POXS	ATS01604PEXS	ATS01604POS	ATS01604PES	ATS01604PO3S	ATS01604PE3S
	200	ATS02004POXS	ATS02004PEXS	ATS02004POS	ATS02004PES	ATS02004PO3S	ATS02004PE3S
2	250	ATS02504POXS	ATS02504PEXS	ATS02504POS	ATS02504PES	ATS02504PO3S	ATS02504PE3S
	320	ATS03204POXS	ATS03204PEXS	ATS03204POS	ATS03204PES	ATS03204PO3S	ATS03204PE3S
3	400	ATS04004POXS	ATS04004PEXS	ATS04004POS	ATS04004PES	ATS04004PO3S	ATS04004PE3S
	500	ATS05004POXS	ATS05004PEXS	ATS05004POS	ATS05004PES	ATS05004PO3S	ATS05004PE3S
	630	ATS06304POXS	ATS06304PEXS	ATS06304POS	ATS06304PES	ATS06304PO3S	ATS06304PE3S

**Spares**



ATS Controller CM-331 & CM-335	Booking Reference Code
CM-331 Controller Spares	ATSCONTROLLER331SP
CM-335 Controller Spares	ATSCONTROLLER335SP



ATS DGPS	Booking Reference Code
DGPS1P For CM-331 Controller Spares	ATSCONTPOSUP331SP
DGPS2P For CM-335 Controller Spares	ATSCONTPOSUP335SP

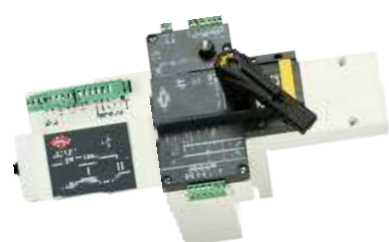

ATS PCB & Motor Module	Booking Reference Code
ATS PCB & Motor Module FR-0 40A Spares	ATSPCBMODFR040ASP
ATS PCB & Motor Module FR-0 63A Spares	ATSPCBMODFR063ASP
ATS PCB & Motor Module FR-0 80A Spares	ATSPCBMODFR080ASP
ATS PCB & Motor Module FR-0 100A Spares	ATSPCBMODFR0100ASP
ATS PCB & Motor Module FR-0 125A Spares	ATSPCBMODFR0125ASP



ATS PCB Module	Booking Reference Code
ATS PCB Module FR-1 125A Spares	ATSPCBMODFR1125ASP
ATS PCB Module FR-1 160A Spares	ATSPCBMODFR1160ASP
ATS PCB Module FR-1 200A Spares	ATSPCBMODFR1200ASP
ATS PCB Module FR-2 250A Spares	ATSPCBMODFR2250ASP
ATS PCB Module FR-2 320A Spares	ATSPCBMODFR2320ASP
ATS PCB Module FR-3 400A Spares	ATSPCBMODFR3400ASP
ATS PCB Module FR-3 630A Spares	ATSPCBMODFR3630ASP



ATS Motor Module	Booking Reference Code
ATS Motor Module FR-1 125A Spares	ATSMOTMODFR1125ASP
ATS Motor Module FR-1 160A Spares	ATSMOTMODFR1160ASP
ATS Motor Module FR-1 200A Spares	ATSMOTMODFR1200ASP
ATS Motor Module FR-2 250A Spares	ATSMOTMODFR2250ASP
ATS Motor Module FR-2 320A Spares	ATSMOTMODFR2320ASP
ATS Motor Module FR-3 400A Spares	ATSMOTMODFR3400ASP
ATS Motor Module FR-3 630A Spares	ATSMOTMODFR3630ASP



ATS Handle Assy	Booking Reference Code
HANDLE ASSLY 40A ATS FR-0 SPARES	ATSHDLASM040ASPFR0
HANDLE ASSLY 63A ATS FR-0 SPARES	ATSHDLASM063ASPFR0
HANDLE ASSLY 80A ATS FR-0 SPARES	ATSHDLASM080ASPFR0
HANDLE ASSLY 100A ATS FR-0 SPARES	ATSHDLASM100ASPFR0
HANDLE ASSLY 125A ATS FR-0 SPARES	ATSHDLASM125ASPFR0
HANDLE ASSLY 125A ATS FR-1 SPARES	ATSHDLASM125ASPFR1
HANDLE ASSLY 160A ATS FR-1 SPARES	ATSHDLASM160ASPFR1
HANDLE ASSLY 200A ATS FR-1 SPARES	ATSHDLASM200ASPFR1
HANDLE ASSLY 250A ATS FR-2 SPARES	ATSHDLASM250ASPFR2
HANDLE ASSLY 320A ATS FR-2 SPARES	ATSHDLASM320ASPFR2
HANDLE ASSLY 400A ATS FR-3 SPARES	ATSHDLASM400ASPFR3
HANDLE ASSLY 630A ATS FR-3 SPARES	ATSHDLASM630ASPFR3

